



Made in India

# OFF-HIGHWAY TYRE-WHEEL SOLUTIONS



Forklift & Warehousing  
Equipment



Skidsteer



Telehandler



Ground Support  
Equipment



Port Trailer



Agricultural  
Implement Equipment



Road Paver

## ABOUT US



Emerald Tyre Manufacturers Limited is India's largest manufacturer and exporter of tyres and wheels for Forklifts, GSE, Port Equipment, and Skid Steers, with special focus in Industrial, Construction and Agri segments.



Emerald is a public listed company in the National Stock Exchange of India (NSE) and a multinational with factories located in India and South Africa.



Our company manufactures range of products that includes Solid tyres, Press on tyres, Industrial pneumatics, Butyl tubes, Wheel rims meant for various applications like Forklift, Skid steers, GSE, Telehandlers, Port trailers, Road pavers, Agri Implements, Lawn and Garden Mowers, Mobile homes besides others.



Started in 2002, Emerald has successfully expanded its global footprint over the years operating across 70 plus Countries through its own Sales office-Warehouse and network of Channel partners.



To strengthen our global reach, we operate through our own dedicated distribution centres in Belgium (Europe), Dubai (RAK Free Zone) and Johannesburg (South Africa), catering to the European, Middle East, and African markets.



Our extensive network of exclusive channel partners, enable just-in-time delivery and fitment solutions to OEMs and end customers.



Emerald serves top OEMs across the globe offering customised tyre and wheel solution within our focused segments.



## MANUFACTURING EXCELLENCE

- State-of-the-art manufacturing facility strategically located near Chennai, India's leading automotive hub, enabling efficient global connectivity, with proximity to port, railways, and airport.
- Strict compliance to GMPs -5S, Kaizen, APQP, and PPAP to ensure consistency in delivering superior quality products over decades across continents.
- ISO 9001:2015 and ISO 14001:2015 certified company.
- Commitment to ESG & Sustainability - All our tyres conform to REACH norms. (European Union regulations for the safe use of chemicals to protect the environment and human health)
- Strong in-house R&D supported by highly qualified professionals and comprehensive testing facilities



## SOLID RESILIENT TYRES

PAGE 4



## PRESS-ON BAND

PAGE 8



## INDUSTRIAL PNEUMATIC TYRES

PAGE 18



## WHEEL RIMS & FITMENT PRESS

PAGE 26



# SOLID RESILIENTS

*Solid in Performance*



## FEATURES

- Unique tread design for improved traction & low rolling resistance
- Soft-Resilio layers for increased driving comfort and reduced equipment maintenance
- High-durometer hard base compound for lower deflection and excellent stability
- Optimum interference fit base for secure fitment
- Available in FRRC & Bead Wire base and also in Lip / Click / Easy Fit (EF) versions
- Specialty versions include Non-Markers, Heat-Resistant, Oil-Resistant, Anti-Static, Aqua-Grip, Sub-Zero, Cut-Resistant, Anti-Abrasive, Anti-Skid tyres, etc.,
- Tyres designed as per T&RA & ETRTO standards
- Resilients available in different versions to meet the variable demands of operations

## KEY APPLICATIONS

- FORK LIFTS
- SKIDSTEER
- GROUND SUPPORT EQUIPMENT
- PORT TRAILERS
- INDUSTRIAL TRAILERS
- PLATFORM TRUCKS
- FARM TRUCKS
- REACH STACKERS
- EMPTY CONTAINER HANDLERS
- ACCESS / WAREHOUSE EQUIPMENT
- OTHER MATERIAL HANDLING APPLICATIONS

## AXIMO ULTIMATE

Highly recommended for round the clock applications operating in strenuous work environment



Top notch product of Emerald designed for enhanced resistance to cut damages

Higher NSD for exceptional life and performance

Designed for both tough indoor and outdoor 3-shift usage applications

Exceptional XT compound for long wear and extended durability

Unique tread design for improved traction & excellent braking both in wet and dry conditions

Wider tread profile for improved foot print and stability

Cooler running heavy-duty compound for exceptional round the clock performance



## EMPOWER SUPER PREMIUM

Highly recommended for round the clock applications operating in tough work environment

## GRECKSTER GOLD PRIME

Highly recommended for round the clock operations performance



Heavy duty compound for excellent life & performance

Wider foot print tread design with center wear bar for excellent stability and even wear

Reinforced sidewall to resist cut damages

Optimum resilient layers for equipment care and increased driver comfort

# EMERALD

High Natural rubber based tread compound that guarantees optimum life & performance

Optimum interference fit for secure fitment

Time tested Y lug design for assured performance

Soft resilio layers for excellent shock absorption property



## GRECKSTER STANDARD

Signature product of Emerald with classic Y-Lug design

## SOLID PLUS ECONOMY

Value for money product for low hours usage applications operating in standard work environment



Two layer construction

Classic Y-Lug design

Tread compound optimized for improved life

Sidewall protector to prevent damages from external hit

## SPECIALITY TYRES

Emerald addresses diverse material handling demands with application-based, customized speciality tyre solutions beyond a single compound approach.



VERSION	ENVIRONMENT	FOCUS INDUSTRY
 NON-MARKERS	CLEAN FLOOR, EPOXY COATED	PHARMA, FOOD & BEVERAGE
 HEAT-RESISTANT	HIGH AMBIENT TEMPERATURE	FOUNDRY, SMELTER PLANT
 OIL-RESISTANT	OILY	PETROCHEMICAL, EDIBLE OIL PLANT
 CUT-RESISTANT	SHARP-EDGED WORKPLACE HAZARD	BOTTLING, GLASS, IRON & STEEL PLANT
 ANTI-STATIC	ELECTRICALLY CONDUCTING	DEFENCE, CHEMICAL
 AQUA-GRIP	WET, SNOW, SLIPPERY	GENERAL
 ANTI-ABRASIVE	RIBBED, CONCRETE FLOOR	GENERAL
 ANTI-SKID	INCLINED SURFACE, ACCESS RAMP	GENERAL

**Caution:** Non-Marker should always be used with Earthing Strips to avoid static electricity build up.

# TECHNICAL SPECIFICATION

#LOAD CAPACITY in kg for Forklift Truck upto 25 kmph

SIZE	RIM WIDTH (inch)	VARIANT					NOMINAL		LOAD CAPACITY IN KG	
		AXIMO ULTIMATE	EMPOWER SUPER PREMIUM	GRECKSTER GOLD PRIME	GRECKSTER STANDARD	SOLID PLUS ECONOMY	OD (inch)	SW (inch)	LOAD WHEEL	STEER WHEEL
3.00 x 4 (R)	2.10 - 2.50				•	•	9.90	3.30	260	195
3.00 x 4 (W)	2.10				•	•	9.90	3.30	260	195
3.50 x 4 (R)	2.50				•	•	10.00	3.50	260	195
4.00 x 4 (R)	2.50				•	•	11.80	3.60	525	410
3.20 - 8 (R)	3.00				•	•	8.90	4.05	770	590
100 / 75 - 8 (S)	3.00						14.17	3.75	755	580
100 / 80 - 8 (S)	2.50 / 3.00						14.20	3.75	755	580
100 / 80 - 8 (RIB)	2.50 / 3.00				•		14.2	3.8	755	580
4.00 x 8 (R/Y)	3.00 / 3.75				•	•	16.00	3.90	950	730
5.00 x 8	3.00 / 3.50 (Y) / 3.75(W) / 4.50	•	•	•	•	•	17.90	4.90	1420	1090
12 x 4 - 8 (R)	3.00				•	•	11.70	3.90	650	550
12 x 6 - 8 (R)	5.00						11.81	5.91		
15½ X4 - 8 (R)	2.50				•		15.50	3.75	1040	800
15½ X5 - 8 (R)	2.50				•		15.50	5.00	1300	1000
15 x 4 ½ - 8 (125/75 - 8)	3.00 / 3.25	•	•	•	•	•	15.20	4.50	1040	800
16 x 6 - 8 (150/75 - 8)	4.33	•	•	•	•	•	16.00	6.40	1495	1150
17 X 7 - 8 (S)	4.33		•				16.8	5.87	1860	1430
18 x 7 - 8 (180/70 - 8)	4.33	•	•	•	•	•	18.00	5.90	2145	1650
18 x 9 - 8	7.00				•	•	18.00	8.00	2300	1900
140 / 55 - 9	4.00			•			15.40	5.60	1170	900
6.00 x 9	4.00	•	•	•	•	•	20.60	5.60	1885	1450
20 x 6 - 9 (S)	4.00				•	•	19.45	5.50		
20 x 8 x 9 (S)	6.00				•	•	19.45	7.50		
21X6-9 (6.00-9)	4.00					•	21.00	5.25	2000	1550
21 x 8 - 9 (200/75 - 9)	6.00	•	•	•	•	•	20.70	7.60	2755	2120
4.00 x 9.75 (R)	3.75				•	•	16.80	4.80		
200 / 50 - 10	6.50	•	•	•	•	•	17.80	7.40	2470	1900
23 x 9 - 10 (225/75 - 10)	6.50	•	•	•	•	•	22.50	8.30	3445	2650
6.50 x 10	5.00	•	•	•	•	•	22.70	6.30	2340	1800
6.50 x 10	5.50				•	•	22.70	6.30	2570	1975
7.50 x 10	5.50				•	•	25.70	7.10	3070	2360
560 x 165 x 11	5.00				•	•	21.70	6.44		
315 / 45 - 12	10.00			•			22.70	11.00	3769	2900
"23 x 10 - 12 (250/60 - 12)"	8.00	•	•	•	•	•	23.30	9.65	3770	2900
7.00 x 12	5.00	•	•	•	•	•	25.40	6.90	2920	2240
"27 x 10 - 12 (250/75 - 12)"	8.00	•	•	•	•	•	25.60	9.80	3900	3000
"28 x 12.5 - 15 (355/45 - 15)"	9.75	•	•	•	•	•	27.10	12.40	5525	4250
"32 x 12.1 - 15 (355/65 - 15) (350 - 15)"	9.75	•	•		•	•	32.28	11.80	7800	6000
250 x 15 (250/70 - 15)	7.00 / 7.50	•	•	•	•	•	28.90	9.30	4750	3650
300 x 15 (315/70 - 15)	8.00	•	•	•	•	•	32.30	10.10	5850	4500
400 / 60 - 15	11.00		•				32.10	12.90	8700	6750
6.00 x 15	4.50				•	•	27.40	5.90	2455	1820
7.00 x 15	5.50 / 6.00 / 6.50	•	•	•	•	•	27.60	7.50	3545	2725
7.50 x 15	5.50 / 6.00 / 6.50	•	•	•	•	•	28.30	7.50	3900	3000
"8.15 x 15 (225/75 - 15) (28 x 9 - 15)"	7.00	•	•	•	•	•	27.10	8.40	3900	3000
8.25 x 15	5.50 / 6.50	•	•	•	•	•	30.70	7.90	4750	3650
7.50 x 16	5.50 / 6.00			•	•	•	30.80	7.90	3908	2831
8.00 x 16	5.50				•	•			3965	3050
8.25 x 16	6.00				•	•	30.75	8.00	4750	3650
7.50 x 20	6.00				•	•	34.75	7.05	3840	3200
8.25 x 20	6.50 / 7.00				•	•	38.90	9.10	4400	3675
9.00 x 20	7.00 / 7.50 / 8.00				•	•	40.40	9.50	5340	4450
10.00 x 20	7.50 / 8.00	•	•	•	•	•	40.40	9.50	6000	5000
11.00 x 20	7.50 / 8.00				•	•	41.40	10.35	6510	5245
12.00 x 20 - 42	8.00				•	•	41.40	10.35	6510	5245
12.00 x 20 - 43	8.00 / 8.50	•	•	•	•	•	43.40	11.60	7500	6250
355 / 50 - 20	10.00		•				32.00	12.50	8970	6900
14.00 x 20 (S)	10.00				•	•	48.80	13.10	8250	6800
12.00 x 24	8.50 (S) / 10.00 (Y)				•	•	47.00	11.80	7980	6650
14.00 x 24	10.00				•	•	51.20	13.20	11000	9175
14.00 x 25	10.00				•	•	51.20	13.20	11000	9175

# PRESS-ON BAND

*Bonded for Life*



## FEATURES

- Wear resistant tread compound for extended life
- Wider tread profile for reduced work load
- Low rolling resistance design for higher energy efficiency
- Superior bonding technology for trouble free running
- Wider range covering all popular sizes
- Tread in Smooth & Lug patterns
- Available in Non-Marker also
- Customised compounds available on request

## DIRECT BONDING WHEELS

- Direct bonding wheel designed to customised mounting hole profile
- Designed for enhanced performance using high tensile compound
- Offers superior abrasion resistance & low rolling resistance properties



# TECHNICAL SPECIFICATION

NOMINAL DIMENSIONS (inch)	S	L	R	J	NOMINAL DIMENSIONS (mm)	UPTO 10 kmph		UPTO 16 kmph		UPTO 25 kmph		OTHER AVEHICLES <16kmph
						LOAD WHEEL (kg)	STEER WHEEL (kg)	LOAD WHEEL (kg)	STEER WHEEL (kg)	LOAD WHEEL (kg)	STEER WHEEL (kg)	
8.5 x 4 x 4	•					678	558	604	505	491	403	480
10 x 4 x 6 ¼	•					785	640	699	582	565	461	
10 x 4 x 6 ½		•			254 x 102 x 165	780	640	695	585	565	465	555
10 x 5 x 5		•				1100	900	980	825	800	655	
	•				250 x 130 x 140	1065	870	948	792	775	635	
	•				250 x 130 x 145	1065	870	948	792	775	635	
	•				250 x 90 x 170	695	570	619	518	500	410	
10 x 5 x 6 ¼	•	•			254 x 127 x 158.8	1030	840	915	770	745	610	730
	•				300 x 100 x 203	925	755	823	687	635	520	
10 x 5 x 6 ½	•	•				1010	830	905	760	735	605	
	•				300 x 75 x 220	690	560	610	510	470	390	
					300 x 75 x 240					430	350	
12 x 4 - DBW			•			905	745	810	890	660	540	905
12 x 5 x 8	•					1190	980	1065	890	865	710	
12 x 5 1/2 x 8		•			305 x 140 x 203.2	1340	1100	1195	1005	970	795	1100
13 x 3 x 8	•					785	645	705	590	570	470	
13 x 3 ½ x 8		•				870	710	774	646	626	511	
13 x 4 ½ x 8		•			330 x 114 x 203.2	1120	920	1000	840	815	665	800
13 x 5 ½ x 8		•			343 x 140 x 203.2			1345	1130			
13 ½ x 5 x 8	•					1290	1055	1148	960	929	760	
14 x 4 ½ x 8	•	•			356 x 114 x 203.2	1170	960	1045	875	845	695	830
14 x 5 x 10	•					1335	1090	1188	992	961	785	
	•				360 x 75 x 270							535
	•				365 x 160 x 220	1880	1545	1680	1410	1365	1120	1340
14 x 5 - 10		•			356 x 127 x 254	1335	1090	1188	992	961	785	1090
15 ½ x 5 x 10	•	•			394 x 152 x 254	1870	1530	1665	1400	1070	880	1330
	•				400 x 100 x 310			1000	800			
		•			405 x 100 x 305	1160	950	1032	865	835	684	
		•			405 x 120 x 305			1300	875			
	•				425 x 150 x 305	1570	1290	1400	1180	1145	935	1120
	•				425 x 260 x 305	3325	2730	2970	2495	2415	1980	2375
	•				425 x 300 x 305	4245	3485	3790	3185	3085	2530	
		•			430 x 160 x 320	1980	1630	1770	1485	1435	1180	1410
	•				450 x 300 x 305	4656	3815	4144	3472	3352	2747	
15 X 4 X 11 1/2			•		380 x 100 x 295	1050	860	945	790	770	630	875
		•			603 x 220 x 480	3556	2921	3174	2668	2576	2111	2539
	•				620 x 200 x 410	3790	3110	3380	2840	2745	2250	3110
	•				645 x 220 x 410	4329	3537	3762	3087	3060	2448	2812.5
	•				680 x 300 x 470	2886	2358	2508	2058	2040	1632	1875
16 x 5 - DBW			•			1400	1150	1250	1050	1013	831	1000
16 x 5 x 10 ½	•	•		•	406 x 127 x 266.7	1510	1240	1345	1130	1095	900	1080
16 x 6 x 10 ½	•	•		•	406 x 152 x 266.7	1910	1570	1710	1435	1385	1135	1360
16 x 7 x 10 ½		•				2325	1910	2070	1740	1685	1380	
15 x 5 x 11¼	•					1390	1140	1240	1040	1015	830	
15 x 6 x 11¼	•					1715	1410	1530	1285	1250	1025	
16 x 6 x 11 ½		•			406 x 152 x 295	1738	1429	1556	1306	1260	1033	1238
16 ¼ x 5 x 11¼	•	•		•	413 x 127 x 285.8	1530	1250	1360	1145	1110	910	1090

\*S - Smooth L - Lug R - Rib J - Traction

NOMINAL DIMENSIONS (inch)	S	L	R	J	NOMINAL DIMENSIONS (mm)	UPTO 10 kmph		UPTO 16 kmph		UPTO 25 kmph		OTHER VEHICLES <16kmph
						LOAD WHEEL (kg)	STEER WHEEL (kg)	LOAD WHEEL (kg)	STEER WHEEL (kg)	LOAD WHEEL (kg)	STEER WHEEL (kg)	
16 ¼ x 6 x 11¼	•	•		•	413 x 152 x 285.8	1920	1580	1715	1440	1395	1140	1370
16¼ x 7 x 11¼	•	•				2325	1900	2060	1735	1685	1385	
17 x 5 x 12 ½		•			432 x 127 x 308	1570	1290	1400	1180	1145	935	1120
17¼ x 5 x 11¼ - DBW		•			438 x 127 x 285.8	1624	1327	1444	1215	1178	966	1157
		•			450 x 130 x 320	1910	1570	1700	1435	1385	1135	1365
		•			450 x 160 x 320	2250	1845	2000	1685	1630	1335	1605
18 x 5 x 12 ½	•	•		•	457 x 127 x 308	1640	1350	1470	1230	1195	980	1170
18 x 6 x 12 ½	•	•		•	457 x 152 x 308	2100	1720	1870	1575	1520	1245	1500
18 x 7 x 12 ½	•	•		•	457 x 178 x 308	2550	2100	2280	1910	1855	1520	1820
18 x 8 x 12 ½	•	•		•	457 x 203 x 308	3000	2475	2680	2250	2180	1785	2150
18 x 9 x 12 ½	•	•		•	457 x 229 x 308	3450	2850	3090	2600	2520	2065	2475
		•			500 x 160 x 370	2338	1920	2084	1754	1698	1391	1669
20 x 4 x 16			•			1505	1230	1339	1119	1084	886	
20 x 6 x 16			•		508 x 152 x 406.4	2218	1822	1982	1666	1614	1322	1586
20 x 8 x 16			•		508 x 203 x 406.4	3010	2470	2685	2255	2185	1790	2150
20 x 9 x 16			•			3445	2820	3066	2566	2480	2030	
21 x 5 x 15 - DBW		•			533 x 127 x 381	1840	1510	1640	1385	1335	1095	1320
21 x 6 x 15		•				2185	1790	1945	1629	1705	1400	
21 x 7 x 15	•	•		•	533 x 178 x 381	2875	2350	2560	2150	2085	1710	2050
21 x 8 x 15	•	•			533 x 203 x 381	3375	2775	3025	2540	2455	2010	2425
21 x 9 x 15		•		•	533 x 229 x 381	3900	3200	3475	2920	2835	2325	2775
	•				550 x 160 x 410	2450	2000	2180	1830	1770	1450	1740
22 x 6 x 16		•		•	559 x 152 x 406.4	2450	2000	2180	1830	1765	1450	1740
22 x 7 x 16		•			559 x 178 x 406.4	2975	2450	2650	2230	1765	1450	2125
22 x 8 x 16	•	•		•	559 x 203 x 406.4	3500	2875	3130	2625	2545	2085	2500
22 x 9 x 16	•	•		•	559 x 229 x 406.4	4050	3325	3600	3025	2940	2410	2875
22 x 10 x 16		•			559 x 254 x 406.4	4570	3745	4067	3408	3320	2725	3250
22 x 12 x 16		•			559 x 305 x 406	5640	4620	5020	4204	4095	3360	4025
22 x 12 x 17 ¾	•	•			559 x 305 x 451	4690	3850	4180	3520	3400	2790	3350
22 x 14 x 16	•	•			559 x 356 x 406	6710	5500	5972	5005	4831	3960	
22 x 16 x 16	•	•				7760	6360	6906	5788	5587	4579	
		•			580 x 340 x 406	6700	5505	5980	5025	4865	3990	4785
	•				620 x 420 x 480	7908	6473	7038	5889	5694	4660	
	•				645 x 250 x 410	4810	3930	4180	3430	3305	2745	
		•			645 x 350 x 410	7070	5787	6154	5052	4865	4037	4591
	•				630 x 200 x 480	3525	2885	3137	2625	2538	2077	
	•				630 x 220 x 480	3878	3174	3451	2888	2792	2285	4329
	•				645 x 250 x 480	4670	3825	4156	3481	3362	2754	
	•				660 x 200 x 480	3954	3248	3529	2967	2864	2348	2823
26 x 8.5 x 15	•				660 x 216 x 380	4890	4029	4368	3666	3549	2910	3506
26 x 10 x 19	•				660 x 250 x 480	4710	3881	4207	3531	3419	2803	3377
26 x 6 x 20	•				660 x 152 x 508	2755	2255	2452	2052	1984	1624	
26 x 7 x 20	•				660 x 178 x 508	3375	2775	3000	2525	2445	2005	2400
26 x 8 x 20	•				660 x 203 x 508	3975	3275	3550	2980	2885	2365	2850
28 x 12 x 22	•	•			711 x 305 x 559	6750	5530	6008	5032	4905	4020	4800
28 x 15 x 22	•	•			711 x 381 x 559	8700	7130	7743	6488	6264	5134	
28 x 16 x 20	•				711 x 406 x 500	9735	8000	8695	7300	7055	5795	6950
28 x 16 x 22	•				711 x 406 x 559	9280	7600	8259	6916	6770	5550	
	•				920 x 240 x 670	5045	4145	4500	3780	3660	3000	
	•				920 x 400 x 670	8375	6881	7470	6275	6076	4980	5976
33 x 12 x 22	•				840 X 305 X 559	7800	6381	6789	5571	5469	4457	5773
33 x 14 x 22	•				840 X 355 X 559	9100	7445	7920	6500	6380	5200	6735
33 x 16 x 22	•				840 X 406 X 559	10400	8509	9051	7429	7291	5943	7697
40 x 16 x 30	•				1016 x 406 x 762	12420	10160	10810	8870	8550	7095	8060
40 x 20 x 30	•				1016 x 508 x 762	16120	13180	14020	11520	11090	9210	10460

# SKIDSTEER SOLIDS



## FEATURES

- Skidsteer tyre range available both in solids and pneumatics
- Solid tyres offered with aperture and non-aperture profile
- Base options available in both lip and standard profile in solids
- Solid tyres covering popular sizes in 16" and 20" ID
- Available in R4, industrial tread pattern
- Heavy duty compound for round the clock operations
- Ready to fit tyre wheel options for select sizes
- Smooth pattern in 16" and 20" ID under development



R4 WITH APERTURE



R4 WITHOUT APERTURE



## SOLID TYRES - R4 WITHOUT APERTURE

- Cut – chip resistant tread
- Step lug for improved traction on soft surfaces
- Heavy duty compound for tougher applications
- Reinforced sidewall design for reduced impact and rim protection

SIZE	RIM SIZE	EQUIVALENT PNEUMATIC SIZE	OD (INCH)	SW (INCH)	TREAD PATTERN	SIDEWALL PROFILE	LOAD RATING @ 10 KMPH IN KGS
30x9-16	6.00-16	10-16.5	30.20	8.60	R4	Standard	2690
30x10-16	6.00-16	10-16.5	30.80	9.80	R4	Standard	4175
31x10-20	7.50-20	10-16.5	30.80	9.40	R4	Standard	3750
33x12-20	7.50-20	12-16.5	32.70	11.20	R4	Standard	4405



## SOLID TYRES - R4 WITH APERTURE

- Engineered for comfortable ride and reduced operator fatigue
- Apertures for cooler running and longer life
- High abrasion resistant tread
- Designed for Heavy duty cycle

SIZE	RIM SIZE	EQUIVALENT PNEUMATIC SIZE	OD (INCH)	SW (INCH)	TREAD PATTERN	SIDEWALL PROFILE	LOAD RATING @ 10 KMPH IN KGS
30x10-16	6.00-16	10-16.5	30.80	9.80	R4	Aperture	2990
31x10-20	7.50-20	10-16.5	30.80	9.40	R4	Aperture	2810
33x12-20	7.50-20	12-16.5	32.70	11.20	R4	Aperture	2965



## SOLID TYRES - INDUSTRIAL WITHOUT APERTURE

- High rubber to void ratio for improved contact patch
- Wider footprint for improved stability and optimum wear

SIZE	RIM SIZE	EQUIVALENT PNEUMATIC SIZE	OD (INCH)	SW (INCH)	TREAD PATTERN	SIDEWALL PROFILE	LOAD RATING @ 10 KMPH IN KGS
8.25-16	6.00-16	10-16.5	30.75	8.00	Industrial	Standard	3900

# GSE TYRES & WHEELS



## FEATURES

- Size range covering all popular sizes in GSE segment both in Solid and Pneumatics
- Two-stage & Three-stage Construction in Solids
- Resilio Layers for soft ride
- Applications include Baggage & Pallet Trolley, Container / Pallet Dolly
- 4.00 - 8 Supplied as TYRE-WHEEL assembly
- 4.00 x 8 available in rim width 2.50/2.75/3.00/3.25/3.75 (inch)



## GSE TYRE-WHEEL SOLUTIONS



Comprehensive range of GSE tyres available in Solid and Pneumatics



Value addition in the supply of Solid and Pneumatic Tyre-Wheel assembly



Popular sizes in GSE rib and industrial lug pattern



Select solid sizes available in both Aperture and Non Aperture



Solids available in both Lip/Click and standard base profile



Tyre wheel assembly solutions in Single, Split and lock ring versions



### BAGGAGE TOW TRACTOR

SOLID

SIZE	RIM WIDTH	LUG	GSE RIB - APERTURE
5.00x8	3.00	•	
6.90/6.00x9	4.00	•	•
6.50x10	5.00	•	•
7.00x12	5.00	•	•
8.15x15 (28x9-15)	7.00	•	

PNEUMATIC

SIZE	PLY RATING	LUG	GSE-RIB
5.00x8	8 PR	•	
6.90/6.00x9	10/12 PR	•	•
6.50x10	12/14 PR	•	•
7.00x12	14/16 PR	•	•
8.15x15 (28x9-15)	14/16 PR	•	
8.00x16.5 -TBL	8 PR		•
8.75-16.5 -TBL	10 PR		•



### BAGGAGE CART/DOLLY

SOLID

SIZE	RIM WIDTH	LUG	GSE-RIB	GSE RIB - APERTURE
4.80/4.00x8	3.00/3.75	•	•	
15x41/2-8	3.00/3.25	•	•	
6.90/6.00x9	4.00	•		•
6.50x10	5.00	•		•

PNEUMATIC

SIZE	PLY RATING	LUG	GSE-RIB
4.80/4.00x8	8 PR		•
6.90/6.00x9	10 PR	•	•
6.50x10	12 PR	•	•



### GROUND POWER & A/C UNITS

SOLID

SIZE	RIM WIDTH	LUG	GSE RIB - APERTURE
18x7-8	4.33	•	
21x8-9	6.00	•	
23x9-10	6.50	•	
23x10-12	8.00	•	
7.00-12	5.00	•	•
27x10-12	8.00	•	

PNEUMATIC

SIZE	PLY RATING	LUG	GSE-RIB
18x7-8	8/10 PR	•	
21x8-9	16 PR	•	
23x9-10	18/20 PR	•	
23x10-12	12/16 PR	•	
7.00-12	14/16 PR	•	•
27x10-12	18 PR	•	
20.5x8-10	8 PR	•	





## CARGO LOADER

SOLID

SIZE	RIM WIDTH	LUG
300x15	8.00	•
32x12.1-15	9.75	•
10.00x20	7.50/8.00	•
12.00x20	8.50 /10.00	•
12.00x24	8.50/10.00	•
14.00x24	10.00	•

PNEUMATIC

SIZE	PLY RATING	LUG	GSE-RIB
300x15 (315/70-15)	18/20 PR	•	•
10.00x20	16 PR	•	
12.00x20	18 PR	•	



## PUSH BACK TRACTOR

SOLID

SIZE	RIM WIDTH	LUG
8.25x15	6.50	•
300x15 (315/70-15)	8.00	•
10.00x20	7.50/8.00	•
12.00x20	8.50/10.00	•
12.00x24	8.50/10.00	•
14.00x24	10.00	•

PNEUMATIC

SIZE	PLY RATING	LUG	GSE-RIB
8.25x15	16/18 PR	•	•
300x15 (315/70-15)	18/20/24 PR	•	•
10.00x20	16 PR	•	
12.00x20	18 PR	•	



## MISC. APPLICATIONS

SOLID

SIZE	RIM WIDTH	SMOOTH	LUG
100/80-8	2.50/3.00	•	
7.00-15	5.50/6.00/6.50		•
7.50-16	5.50/6.00		•

PNEUMATIC

SIZE	PLY RATING	LUG	GSE-RIB
6.00-16 TT	6/8 PR		Tractor F
7.50-16	16 PR		•
7.00-15	14/16 PR	•	



## PASSENGER BOARDING BRIDGE

SOLID

SIZE	LUG	SMOOTH / PLAIN
22x14x16	•	•
28x12x22	•	•
28x16x22	•	•
40x16x30		•
40x20x30		•

SOLID

SIZE	RIM WIDTH	GSE-RIB
3.00-4	2.50	•
4.00-4	2.50	•
3.50-4	2.50	•
12x4	DBW	•
16x5	DBW	•



## TOW BAR



# PORT TRAILER TYRES



## FEATURES

- Range of sizes for port terminal and industrial trailer applications
- Cut-Wear Resistant Cooler tread for round the clock operations
- Resilio layers for cushion ride
- Concave sidewall profile to reduce sidewall damages
- High-durometer, Interference-fit hardbase for excellent stability and secure fitment
- 10.00 x 20 - Available in Lug and Slick (Plain) pattern
- 14.00 x 24 & 14.00 x 25 - High profile version are available



SIZE (inch)	RIM WIDTH (inch)	OD (mm)	SW (mm)	# LOAD RATING (kg)		LUG	SMOOTH
				LOAD WHEEL	STEER WHEEL		
8.25 x 20	6.50/7.00/7.50	965	225	4400	2675	•	
9.00 x 20	6.50/7.00/7.50	985	225	5340	4450	•	
10.00 x 20 - 40	6.50/7.00/7.50	1026	242	5620	4650	•	•
11.00 x 20	7.50 / 8.00	1060	263	6510	5425	•	
12.00 x 20 - 42	7.50 / 8.00	1060	263	6510	5425	•	
12.00 x 20 - 44	8.00 / 8.50	1102	295	7500	6113	•	
12.00 x 20	10.00	1102	295	7500	6113	•	
12.00 x 24	8.50	1190	288	7980	6650	•	
12.00 x 24	10.00	1190	325	9000	7500	•	
14.00 x 24	10.00	1320	332	11000	9175	•	
14.00 x 25	11.25	1345	405	12480	10400	•	

OD - Overall Diameter SW - Section or Maximum Width #LOAD CAPACITY upto 25 kmph

# TELEHANDLER SOLIDS

- Solid solutions with puncture proof and extended life advantage
- Popular sizes covering ID16, 20, 24, 25 inches
- Proven tread patterns and compounds for varying applications
- Heavy duty compounds for Soft-Rough-Abrasive-Littered applications
- Total tyre-wheel assembly solutions



SIZE	RIM SIZE	OD (INCH)	SW (INCH)	TREAD PATTERN	SIDEWALL PROFILE	LOAD RATING @ 10 KMPH IN KGS
14.00 x 24	10.00	51.20	13.20	R4	Aperture	10085
14.00 x 25	10.00	51.20	13.20	Industrial	Non - Aperture	11335

# TYRE-WHEEL SOLUTIONS

Emerald as part of value added support to its customers offers tyre-wheel assembly solutions in the following segments

- Split Rims – Solid Resilient & Industrial Pneumatic Tyres
- Wheel Hub - Press-ons
- Multi-piece Rims – Solid Resilient & Industrial Pneumatic Tyres



## BASE CONSTRUCTION

FRRC BASE



BEAD WIRE BASE



## TREAD PATTERN

F LUG



W LUG



G LUG



Y LUG



R RIB



# INDUSTRIAL PNEUMATIC

*Built to Last Longer*

IND01

## FEATURES

- Heavy duty design for tough applications
- Special tread compound for cooler running & wear resistance
- Wider tread profile for improved traction & stability
- Reinforced nylon casing for higher load rating
- Reinforced sidewall for reduced deflection & improved protection
- Rim-guard protector for rim flange area
- Comprehensive skid steer range of sizes in R4, Industrial and deep tread
- Non markers available for clean surface environment



IND04



SKT01



SKT05

# TECHNICAL SPECIFICATION

## FORKLIFT - IND01

SIZE	RIM (inch)	ALTERNATE RIM (inch)	INFLATED DIMENSIONS (mm) +/-2%		NSD		PLY RATING	INFLATION PRESSURE		LOAD CAPACITY (kg) FORK LIFT - upto 25 kmph		
			OD	CROSS SW	(mm)	(32 <sup>nd</sup> of inch)		bar	psi	LOAD WHEEL	STEER WHEEL	SIDE LOADERS
5.00-8	3.00	--	470	145	13.00	16.5/32	8	8.25	117	1235	950	1435
							10	10.00	142	1415	1090	1645
16x6-8	4.33	--	420	158	12.50	15.5/32	18	10.50	150	1540	1185	1790
18x7-8	4.33	--	462	170	17.00	21.5/32	14	9.00	128	1910	1460	2400
							16	10.00	142	2145	1650	2490
							18	10.50	150	2210	1700	2565
21x8-9	6.00	7.00	535	210	18.00	22.5/32	16	10.00	142	2755	2120	3200
6.00-9	4.00	--	540	165	15.50	19.5/32	10	8.50	120	1715	1320	1990
							12	10.00	142	1885	1450	2190
6.50-10	5.00	5.50	598	190	15.50	19.5/32	10	7.75	110	1950	1500	2260
							12	9.00	128	2145	1650	2490
							14	10.00	142	2340	1800	2650
7.00-12	5.00	--	680	196	15.50	19.5/32	12	8.50	120	2680	2060	3110
							14	9.00	128	2755	2120	3200
							16	10.00	142	2910	2240	3400
23x9-10	7.00	--	590	235	18.50	23.5/32	18	9.00	128	3160	2430	3670
							20	10.00	142	3445	2650	4000
27x10-12	8.00	--	692	252	21.50	27.0/32	12	7.25	103	3250	2470	4275
							16	8.00	114	3900	3000	4530
23x10-12	8.00	--	605	260	15.50	19.5/32	18	9.00	128	3385	2605	3935
7.00-15	5.50	--	750	200	18.00	22.5/32	12	8.25	117	3070	2360	3565
							14	9.25	132	3280	2525	3810
							16	10.00	142	3545	2725	3990
7.50-15	6.00	5.50,6.50	780	218	18.00	22.5/32	14	9.25	132	3640	2800	4230
							16	10.00	142	3810	2930	4425
8.15-15	7.00	--	725	219	18.00	22.5/32	12	8.25	117	3445	2650	4000
							14	10.00	142	3900	3000	4530
							16	10.50	150	4010	3085	4660
250-15	7.00	7.50	747	250	18.00	22.5/32	16	8.25	117	4355	3350	5060
300-15	8.00	--	840	300	22.00	27.5/32	16	6.00	85	5130	3945	5955
							18	7.50	107	5845	4495	6785
							20	9.00	128	6500	5000	7550
8.25-15	6.50	6.00/7.00	840	235	21.00	26.5/32	14	8.00	114	4225	3250	4910
							16	9.25	132	4615	3550	5345

## FORKLIFT - IND04

SIZE	RIM (inch)	ALTERNATE RIM (inch)	INFLATED DIMENSIONS (MM) +/-2%		NSD		PLY RATING	INFLATION PRESSURE		LOAD CAPACITY (KG) FORK LIFT - UPTO 25 KMPH		
			OD	CROSS SW	(mm)	(32 <sup>nd</sup> of inch)		bar	psi	LOAD WHEEL	STEER WHEEL	SIDE LOADERS
5.00 - 8	3.00	--	473	135	12.50	16/32	8	8.25	117	1235	950	1435
6.90/6.00 - 9	4.00	--	540	160	14.00	17.5/32	10	8.50	121	1715	1320	1990
6.50 - 10	5.00	5.50	600	185	15.50	19.5/32	10	7.75	110	1950	1500	2260
7.00 - 12	5.00	--	685	195	16.80	21/32	14	9.00	128	2755	2120	3200
8.15 - 15	7.00	--	715	219	18.50	23/32	14	10.00	142	3900	3000	4530
8.25 - 15	6.50	6.00/7.00	845	240	18.00	22.5/32	14	8.00	114	4225	3250	4910
10.00 - 20	7.50	8.00	1088	290	37	47/32	16	8.00	115	6085	5140	8320
12.00 - 20	8.50	8.00	1153	333	37	47/32	16	7.00	100	6980	5895	9840

Also available in Greckster Gold Premium version



## SKIDSTEER - SKT01 (R4)

- Open self-cleaning lug profile
- Specially designed tread pattern for higher torque
- Robust sidewall protects against damages

SIZE	TYPE	RIM (inch)	INFLATED DIMENSIONS (MM) +/- 2%		NSD		PLY RATING	INFLATION PRESSURE		LOAD CAPACITY (kg)	
			OD	CSW	mm	(32nd of Inch)		bar	psi	8 kmph SPEED	16 kmph SPEED
18 x 8.50 - 10	TL	6.00	475	210	12.50	16/32	4	1.50	22	-	-
23 x 8.50 - 12	TL	7.00	590	215	10.00	13/32	6	3.50	50	820	582
23 x 8.50 x 12	TL	7.00	575	215	10.00	13/32	12	6.6	90	1195	940
25 x 8.50 - 14	TL	7.00	655	220	13.00	16.5/32	6	3.50	50	965	762
27 x 8.50 - 15	TL	7.00	695	220	12.00	15/32	6	3.10	45	1121	-
27 x 10.5 - 15	TL	8.50	695	280	12.50	16/32	6	3.10	45	1185	-
10 - 16.5	TL	8.25	775	275	17.00	21.5/32	8	4.10	60	1875	1480
							10	5.20	72	2140	1690
12 - 16.5	TL	9.75	835	320	20.00	25/32	10	4.10	60	2425	1920
							12	4.80	70	2655	2100
14 - 17.5	TL	10.50	945	360	17.50	22/32	14	5.50	80	3875	3061
15 - 19.5	TL	12.25	1025	390	15.50	19.5/32	14	4.80	70	4565	3606



## SKIDSTEER - SKT05 (L5)

- Deep lug & heavy duty tread compound for extended life
- Abrasive resistant tread resists puncture & cut damages
- Reinforced carcass construction for enhance performance
- Rim guard protector to avoid tyre-wheel damage

SIZE	TYPE	RIM (inch)	INFLATED DIMENSIONS (MM) +/- 2%		NSD		PLY RATING	INFLATION PRESSURE		LOAD CAPACITY (kg)	
			OD	CSW	mm	(32nd of Inch)		bar	psi	8 kmph SPEED	16 kmph SPEED
10 - 16.5	TL	8.25	802	262	37	47/32	14	6.3	90	2375	1875
12 - 16.5	TL	9.75	852	305	37	47/32	14	6.3	90	3120	2465



## SKIDSTEER - HD PATTERN

- Deep tread lugs assure maximum tyre life
- Low heat build up compound for cooler running
- Built tough to last longer

SIZE	TYPE	RIM (inch)	INFLATED DIMENSIONS (MM) +/- 2%		NSD		PLY RATING	INFLATION PRESSURE		LOAD CAPACITY (kg)	
			OD	CSW	mm	(32nd of Inch)		bar	psi	8 kmph SPEED	16 kmph SPEED
10 - 16.5	TL	8.25	796	265	33	41.5/32	10	5.2	73	2140	1690



## SKIDSTEER - IND01

- Heavy duty design for tough applications
- Wider tread profile for improved traction & stability
- Unique sipes in shoulder area for enhanced heat dissipation

SIZE	TYPE	RIM (inch)	INFLATED DIMENSIONS (MM) +/- 2%		NSD		PLY RATING	INFLATION PRESSURE		LOAD CAPACITY (kg)	
			OD	CSW	mm	(32 <sup>nd</sup> of Inch)		bar	psi	8 kmph SPEED	16 kmph SPEED
10 - 16.5	TL	8.25	796	265	33	41.5/32	10	5.2	73	2140	1690
12 - 16.5	TL	9.75	865	320	33.5	42/32	12	4.8	70	2655	2100



## WINTER

- Unique tread design for better traction
- Sipes in tread buttons for better aqua planning
- Specially designed tread compound for cold temperatures

SIZE	TYPE	RIM (inch)	INFLATED DIMENSIONS (mm) +/- 2%		NSD		PLY RATING	INFLATION PRESSURE		SIDE LOADER LOAD CAPACITY (kg) upto 25 kmph		
			OD	CSW	(mm)	(32 <sup>nd</sup> of inch)		bar	psi	LOAD WHEEL	STEER WHEEL	STATIC
6.00-9	TL	4.00	540	165	15.50	19.5/32	10	9	120	1715	1320	1990
7.00-12	TL	5	680	192	12	15/32	14	9	128	2755	2120	3200



## LAWN AND GARDEN

- Specially designed tread pattern for maximum traction
- Deep tread depth provides longer life
- Reinforced casing gives increased puncture resistance

SIZE	TYPE	RIM (inch)	INFLATED DIMENSIONS (mm) +/- 2%			PLY RATING	LOAD CAPACITY (kg)	SPEED (kmph)	IP (bar)
			OD	CSW					
26 x 12.00 - 12 TRACTION	TL	10.50	660	310		12	1550	15.0	4.1



## FARM IMPLEMENT

- Wider tread ribs for excellent lateral stability
- Premium tread compound & design for improved rolling resistance
- Wider footprint & flotation design for lower soil compaction

SIZE	TYPE	RIM (inch)	INFLATED DIMENSIONS (MM) +/- 2%		NSD		PLY RATING	INFLATION PRESSURE		LOAD CAPACITY (kg)	
			OD	CSW	mm	(32nd of Inch)		bar	psi	15 kmph SPEED	50 kmph SPEED
9.5L - 15SL	TL	7.00	785	242	7.00	9/32	8	3.03	44	1288	1120
9.5L - 15SL	TL	7.00	790	245	7.00	9/32	12	4.70	68		
11L - 15SL	TL	8.00	785	285	7.50	9.5/32	8	2.50	36	1323	1150
11L - 15SL	TL	8.00	780	280	7.50	9.5/32	12	3.60	52	1668	1450
12.5L - 15SL	TL	10.00	840	320	7.50	9.5/32	8	2.48	36	1564	1360
12.5L - 15SL	TL	10.00	835	320	7.50	9.5/32	12	3.60	52	2013	1750



## AGRICULTURAL IMPLEMENT & TRACTOR TRAILER

- Designed with low section profile for lower soil compaction
- Specially designed for drive and free rolling wheels
- Strengthened casing for higher load capacity

SIZE	TYPE	RIM (inch)	INFLATED DIMENSIONS (mm) +/- 2%			LOAD CAPACITY (kg) FOR FREE ROLLING WHEEL			
			OD	CSW	PLY RATING	30 kmph with HLW		40 kmph with HLW	
						LOAD CAPACITY	IP (bar)	LOAD CAPACITY	IP (bar)
10.0/80 - 12	TL	9.00	710	270	8	1500	4.2	1250	4.0
10.0 / 75 - 15.3	TL	9.00	760	264	10	1800	5	1550	5.1
11.5 / 80 - 15.3	TL	9.00	850	290	12	2575	5.5	2180	5.3
12.5 / 80 - 15.3	TL	9.00	890	305	14	3075	5.7	2650	5.6
12.5 / 80 - 18	TL	9.00	986	320	12	3150	5.0	2650	4.8

SIZE	TYPE	RIM (inch)	APPLICATION	INFLATED DIMENSIONS (MM) +/- 2%		PLY RATING	LOAD CAPACITY (kg) @ 30 kmph	IP(Bar)
				OD	CSW			
7.50 - 16	TT	6.00	TRACTOR TRAILER (TT)	804	216	16	2000	7.6
9.00 - 16	TT	6.00	TT / BACKHOE LOADER	910	240	16	2290	7.4
6.00 - 16	TT	4.50	TRACTOR FRONT	730	163	8	675	4.5

# READING SIZES

## SOLID & PRESS-ON TYRES

Resilient and Press-on sizes are represented in different nomenclature.

Rim width is always shown separately. All Dimensions are nominal.

**6.50 x 10 / 5.00 (Resilient)**

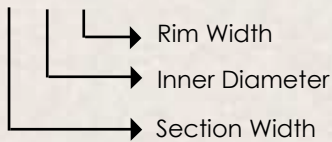

**23 x 9 - 10 / 6.50 (Resilient)**

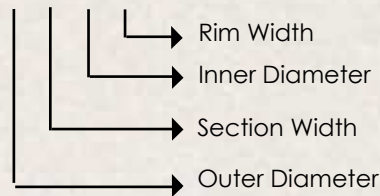

**225 / 75 - 10 ( 6.50 ) (Resilient)**



**18 x 8 x 12 1/8 (Press-on)**

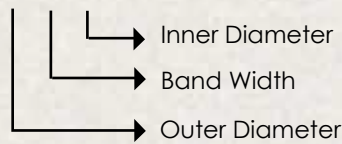

Measurements unspecified above are in Inches

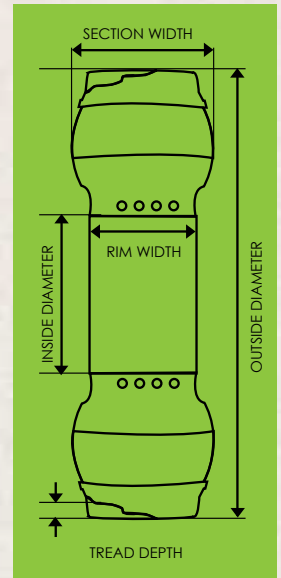

## PNEUMATIC TYRES

Industrial Pneumatics are represented in the following nomenclature

Rim width is always shown separately. All Dimensions are nominal and given in inches

**6.50 x 10 - 14PR NHS**

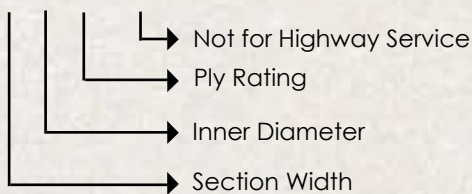

**18 x 7 - 8 - 10PR**

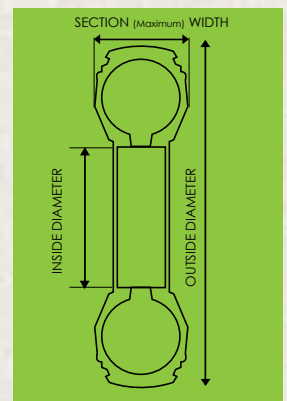
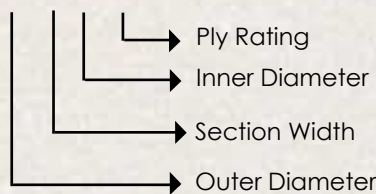

## RECOMMENDATIONS

- All tyre specifications are in accordance with the nominal dimensions of T&RA /ETRT International Standards
- International standards recommend the maximum speed of 25KMPH for forklift trucks and a maximum distance coverage of 2 Kms at a stretch and tyres are designed to conform to these requirements
- International standards specify the nominal overall dia and section width(maximum) of the tyre with corresponding Load rating at differential speeds for varying applications
- The speeds given are the maximum speed in unloaded condition. Higher load at lower speed is not permissible
- Wheel rims to be checked for its correctness of its dimension, profile, load, compatibility with the tyre
- Wheel rims to be checked for its suitability of usage – bereft of cracks, damages, presence of foreign materials to ensure safe operations
- Tyres to be fitted using proper fitment gadgets
- Strict adherence to fitment procedures to be followed for easy, safe and secure fitment
- Tyres should be stored in Dry, Ventilated & Clean conditions
- Exposure to oil / lubricants & Electric currents to be avoided

## LIP TYRES



Lip tyre also called Click, Clip or Easy fit tyre eliminates the usage of end ring and lock ring

Lip tyre base is profiled for firm seating on the circumferential ridge of the rim

Lip and regular base tyre are not inter changable

## LOAD CAPACITY AT VARYING INFLATION PRESSURE

SIZE	PLY RATING	STANDARD INFLATION PRESSURE (psi)	LOAD WHEEL UPTO 25KMPH										
			STD PSI	90 PSI	100 PSI	110 PSI	120 PSI	130 PSI	140 PSI	150 PSI	STD PSI	90 PSI	100 PSI
			5.00-8	8	120	1235	1044	1110	1174	1235	1294	--	--
	10	140	1415	1093	1162	1229	1293	1355	1415	1473	1090	842	895
16x6-8	18	150	1540	1142	1215	1284	1352	1416	1479	1540	1185	879	935
18x7-8	14	130	1910	1540	1638	1732	1823	1910	1995	--	1460	1177	1252
	16	140	2145	1656	1762	1863	1960	2054	2145	2233	1650	1274	1355
	18	150	2210	1639	1743	1843	1940	2033	2123	2210	1700	1261	1341
21x8-9	16	140	2755	2127	2263	2392	2517	2638	2755	2868	2120	1637	1741
6.00-9	10	120	1715	1449	1541	1630	1715	1797	--	--	1320	1116	1186
	12	140	1885	1456	1548	1637	1722	1805	1885	1963	1450	1120	1191
6.50-10	10	110	1950	1734	1844	1950	2052	--	--	--	1500	1334	1419
	12	130	2145	1730	1840	1945	2047	2145	2240	--	1650	1331	1415
	14	140	2340	1807	1922	2032	2138	2241	2340	2436	1800	1390	1478
7.00-12	12	120	2680	2265	2409	2547	2680	2808	--	--	2060	1741	1852
	14	130	2755	2222	2363	2499	2629	2755	2877	--	2120	1710	1818
	16	140	2910	2247	2390	2527	2659	2787	2910	3030	2240	1730	1840
23x9 -10	18	130	3160	2548	2710	2866	3015	3160	3300	--	2430	1960	2084
	20	140	3445	2660	2829	2992	3148	3299	3445	3587	2650	2046	2177
27x10-12	12	105	3250	2970	3159	3340	3514	--	--	--	2470	2257	2400
	16	115	3900	3379	3594	3800	3998	4190	--	--	3000	2599	2764
23x10-12	18	130	3385	2730	2903	3070	3230	3385	3535	--	2605	2101	2234
7.00-15	12	120	3070	2594	2759	2918	3070	3217	--	--	2360	1994	2121
	14	130	3280	2645	2813	2975	3130	3280	3425	--	2525	2036	2166
	16	140	3545	2738	2912	3079	3239	3395	3545	3691	2725	2104	2238
7.50-15	14	130	3640	2935	3122	3301	3473	3640	3801	--	2800	2258	2402
	16	140	3810	2942	3129	3309	3481	3648	3810	3967	2930	2263	2406
8.15-15	12	120	3445	2911	3096	3274	3445	3610	--	--	2650	2240	2382
	14	140	3900	3012	3203	3387	3564	3735	3900	4061	3000	2317	2464
	16	150	4010	2974	3163	3345	3519	3688	3851	4010	3085	2288	2434
250-15	16	120	4355	3680	3914	4139	4355	4564	--	--	3350	2831	3011
300 -15	16	85	5130	5304	5642	--	--	--	--	--	3945	4079	4338
	18	110	5845	5198	5528	5845	6150	--	--	--	4495	3997	4251
	20	128	6500	5290	5626	5949	6259	6559	--	--	5000	4069	4328
8.25-15	14	115	4225	3661	3893	4117	4332	--	--	--	3250	2816	2995
	16	130	4615	3722	3958	4185	4404	4615	4819	--	3550	2863	3045
10.00 - 20	16	115	6085	5272	5607	5929	6238	6537	--	--	5140	4453	4736
12.00 - 20	16	100	6980	6048	6432	6801	7156	--	--	--	5895	5107	5432
10.00 - 20	18	130	6515								5520		
10.00 - 20	20	145	6970								5885		
12.00 - 20	20	120	7740								6560		

## RECOMMENDATIONS

- All tyre specifications are in accordance with the nominal dimensions of the T&RA /ETRTO International Standards
- International standards recommend the maximum speed of 25KMPH for forklift trucks and a maximum distance coverage of 2 Kms at a stretch and tyres meant for this application are designed to conform to these requirements
- The speeds given are the maximum speed in unloaded condition. Higher load at lower speed is not permissible

**LOAD CAPACITY (kg)  
FORK LIFT - upto 25 kmph**

STEER WHEEL UPTO 25KMPH					SIDE LOADERS AT STATIC							
110 PSI	120 PSI	130 PSI	140 PSI	150 PSI	STD PSI	90 PSI	100 PSI	110 PSI	120 PSI	130 PSI	140 PSI	150 PSI
903	950	996	--	--	1435	1213	1290	1364	1435	1504	--	--
947	996	1044	1090	1135	1645	1270	1351	1429	1503	1575	1645	1713
988	1040	1090	1138	1185	1790	1328	1412	1493	1571	1646	1719	1790
1324	1393	1460	1525	--	2400	1935	2059	2177	2290	2400	2506	--
1433	1508	1580	1650	1718	2490	1923	2045	2162	2275	2384	2490	2593
1418	1492	1563	1633	1700	2565	1902	2023	2139	2251	2359	2464	2565
1841	1937	2030	2120	2207	3200	2471	2628	2779	2924	3064	3200	3332
1254	1320	1383	--	--	1990	1682	1789	1891	1990	2085	--	--
1259	1325	1388	1450	1510	2190	1691	1799	1902	2001	2097	2190	2280
1500	1578	--	--	--	2260	2010	2137	2260	2378	--	--	--
1496	1575	1650	1723	--	2490	2008	2136	2258	2376	2490	2600	2707
1563	1645	1724	1800	1874	2650	2046	2177	2301	2421	2538	2650	2759
1958	2060	2159	--	--	3110	2628	2795	2956	3110	3259	--	--
1923	2023	2120	2214	--	3200	2581	2745	2902	3054	3200	3342	--
1945	2047	2145	2240	2332	3400	2626	2793	2953	3107	3256	3400	3540
2204	2319	2430	2538	--	3670	2960	3148	3328	3502	3670	3833	--
2301	2421	2538	2650	2759	4000	3089	3285	3474	3655	3830	4000	4165
2538	2671	--	--	--	4275	3906	4155	4393	4622	--	--	--
2923	3076	3223	--	--	4530	3925	4174	4414	4644	4867	--	--
2362	2486	2605	2720	--	3935	3173	3375	3569	3755	3935	4109	--
2243	2360	2473	--	--	3565	3013	3204	3388	3565	3736	--	--
2290	2409	2525	2637	--	3810	3073	3268	3455	3636	3810	3979	--
2366	2490	2609	2725	2837	3990	3081	3277	3465	3646	3821	3990	4154
2539	2672	2800	2924	--	4230	3411	3628	3836	4036	4230	4417	--
2544	2677	2806	2930	3051	4425	3417	3634	3843	4043	4237	4425	4607
2518	2650	2777	--	--	4000	3380	3595	3801	4000	4192	--	--
2605	2741	2873	3000	3124	4530	3498	3721	3934	4139	4338	4530	4717
2573	2707	2837	2963	3085	4660	3456	3676	3887	4090	4286	4476	4660
3184	3350	3511	--	--	5060	4276	4548	4809	5060	5303	--	--
--	--	--	--	--	5955	6157	6549	--	--	--	--	--
4495	4730	--	--	--	6785	6033	6417	6785	7139	--	--	--
4576	4815	5046	--	--	7550	6144	6535	6909	7270	7619	--	--
3167	3332	--	--	--	4910	4254	4525	4784	5034	--	--	--
3219	3388	3550	3707	--	5345	4310	4584	4847	5100	5345	5582	--
5008	5270	5522	--	--	8320	7209	7667	8106	8530	8939	--	--
5744	6044	--	--	--	9840	8525	9067	9587	10088	--	--	--
					8890							
					9475							
					10560							

- Inflation pressure should be checked and maintained as per the recommendations of the manufacturer
- Over or under inflation would cause premature failure of tyres, high fuel consumption and pose safety related hazards besides high cost of operation
- Tyre removal process should be carried out only in deflated condition by removing the valve insert pin
- Tyres should be stored in Dry, Ventilated & Clean conditions and stacked in vertical position
- Exposure to oil/lubricants & Electric currents should be avoided
- The tyres are not intended for highway service (NHS)

# INDUSTRIAL WHEEL RIMS

*Engineered for Heavy-Duty Applications*

## PRODUCT RANGE

Emerald manufactures a complete range of wheels and hubs for Forklift, Skidsteer, GSE, Port Trailer and Telehandler segments along with tyre-wheel assembly solutions in Solid, Press-on and Industrial Pneumatic Tyres.

- Single Piece Rim
- Split Rim – Zero Offset, Offset & Bearing Housing
- Multipiece Rim - 2 Piece, 3 Piece & 4 Piece wheel rims for customised mounting holes
- Wheel Hub for Press-on Tyre
- Base wheel for Direct Bonded Wheel



## SPECIFICATIONS

WHEEL RIM SIZE	SUITABLE TYRE SIZE	SPLIT RIM	MULTIPIECE RIM
3.00-8	4.00-8 5.00-8 15x41/2-8	•	•
3.25-8	5.00-8 15x41/2-8		•
3.75-8	4.00-8	•	•
4.33-8	18x7-8 16x6-8	•	•
4.00-9	6.00-9	•	•
6.00-9	21x8-9		•
5.00-10	6.50-10 7.50-10	•	•
5.50-10	6.50-10	•	•
6.50-10	23x9-10 200/50-10		•
5.00-12	7.00-12	•	•
8.00-12	23x10-12 27x10-12		•
5.50-15	7.00-15		•
6.00-15	7.00-15 7.50-15		•
6.50-15	7.50-15, 8.25-15		•
7.00-15	8.15-15 250-15	•	•
7.50-15	250-15		•
8.00-15	300-15		•
9.75-15	28x12.5-15 32x12.5-15		•
6.00-16	7.50-16 8.25-16	•	•
7.00-20	9.00-20 10.00-20		•
7.50-20	10.00-20 11.00-20		•
8.00-20	10.00-20 11.00-20 12.00-20		•
8.50-20	12.00-20		•
10.00-20	12.00-20 14.00-20		•
10.00-24	12.00-24 14.00-24		•
10.00-25	14.00-25		•

WHEEL RIM SIZE	TYRE SIZE	SINGLE PIECE RIM	MULTIPIECE RIM
8.25-16.5	10-16.5	•	
9.75-16.5	12-16.5	•	
6.00-16	30x9-16 30x10-16 7.50x16 8.25x16		•
7.50-20	30x10-20 31x10-20 33x12x20		•

## FEATURES

- Manufactured as per ETRTO & T&RA international standards for dimensions and load rating
- High quality Mild Steel - HRPO for improved processability and high quality performance
- Wheel mounting hole profile designed for high precision
- Stringent process and quality control for 100% defect-free product

## RECOMMENDATIONS

- Compatability of Tyre & Wheel to be checked before fitment
- Wheel studs and nut to be torqued to the recommended setting and checked periodically
- Wheel rims to be checked for its deformity, damage, cracks, corrosion
- In case of Pneumatics - Tyres should be fully deflated before demounting the wheel rim
- Fitment of wheel rims to be done by trained personnel using proper fitment tools & gadgets

## FORKLIFT BRANDS

- Toyota
- Linde
- Still
- Jughenrich
- Hyster
- Komatsu
- CAT
- Crown
- CLARK
- HELI
- Nichiyu
- Nissan
- TCM
- Yale
- Doosan
- Hyundai
- Liugong
- Godrej
- OM (Voltas)
- ACE
- and more...

## SKIDSTEER BRANDS

- Bobcat
- CAT
- Manitou
- CASE
- John Deere
- GEHL
- JCB
- Bull
- Liugong
- Gamzen
- and more....

## READING SIZES

### WHEEL RIM TYPES

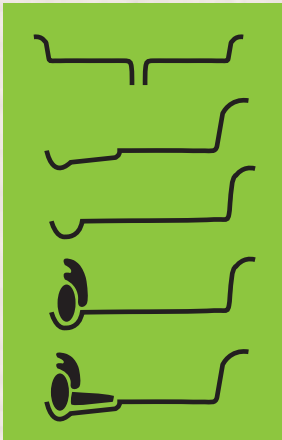

- Two piece Split rim
- Taper - Base rim for Lip tyre
- Flat based rim for Lip tyre
- Three piece rim - End ring, Lock ring
- Four piece taper - Base Rim - End ring, Lock ring, Band

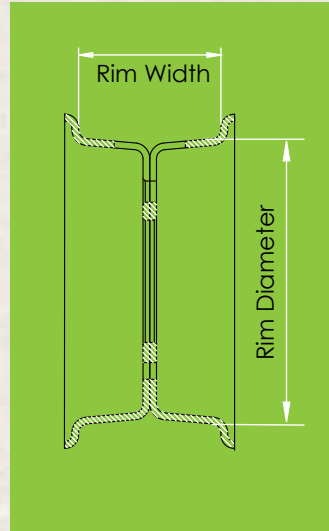

Split Rim sizes are represented as follows  
All Dimensions are in Inches



### SPLIT RIM MEASUREMENTS

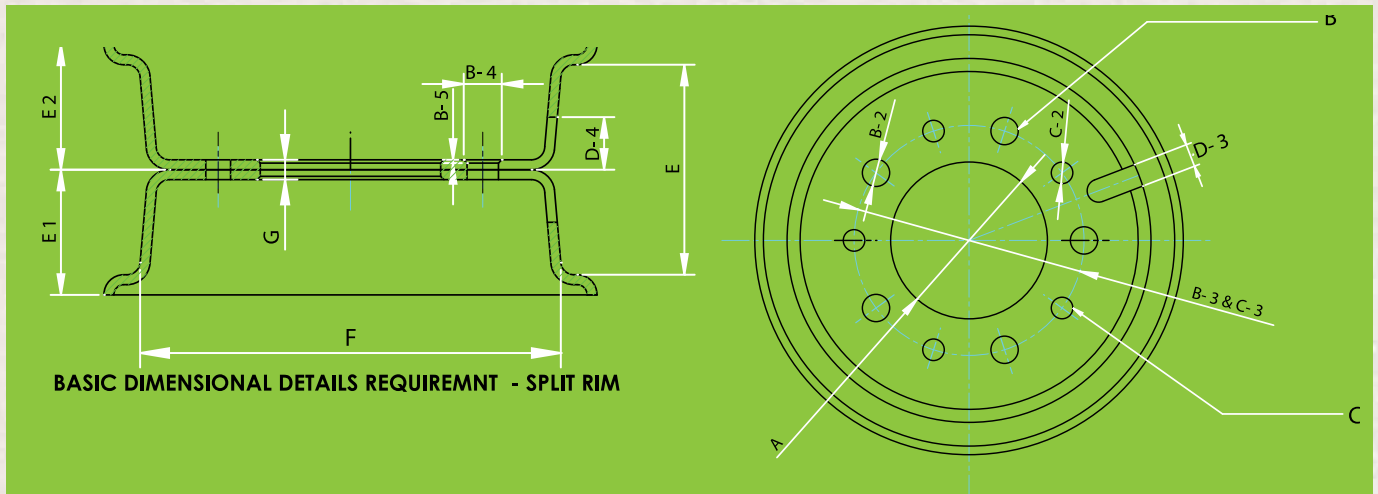

BASIC DIMENSIONAL DETAILS REQUIREMNT - SPLIT RIM

- |                            |                                |   |
|----------------------------|--------------------------------|---|
| A - BORE DIAMETER          | B- 1) No. OF STUD HOLES        | D- 1) VALVE SLOT - INNER (HUB SIDE) CUP |
| B - STUD or HUB HOLES      | B- 2) STUD HOLE DIAMETER       | D- 2) VALVE SLOT - OUTER CUP            |
| C - WHEEL BOLT HOLES       | B- 3) STUD HOLES PCD           | D- 3) VALVE SLOT WIDTH                  |
| D - VALVE SLOT             | B- 4) COUNTER SUNK OUTER DIA   | D- 4) VALVE SLOT DEPTH                  |
| E - RIM WIDTH              | B- 5) COUNTER SUNK DEPTH       |   |
| F - RIM OD                 | C- 1) No. OF WHEEL BOLT HOLES  | E- 1) OFFSET - INNER (HUB SIDE) CUP     |
| G - CENTRE PLATE THICKNESS | C- 2) WHEEL BOLT HOLE DIAMETER | E- 2) OFFSET - OUTER CUP                |
| H - SHEET THICKNESS        | C- 3) WHEEL BOLT HOLES PCD     |   |

### SPLIT RIM HOLE TYPE

#### Types of commonly used Stud Holes

- Through or Straight Hole
- Countersunk holes – Spherical
- Countersunk holes – Conical

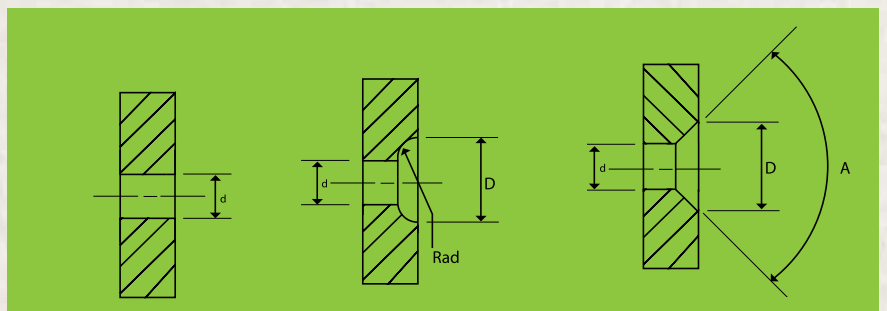

Through or Straight Hole

Countersunk holes (Spherical)

Countersunk holes (Conical)

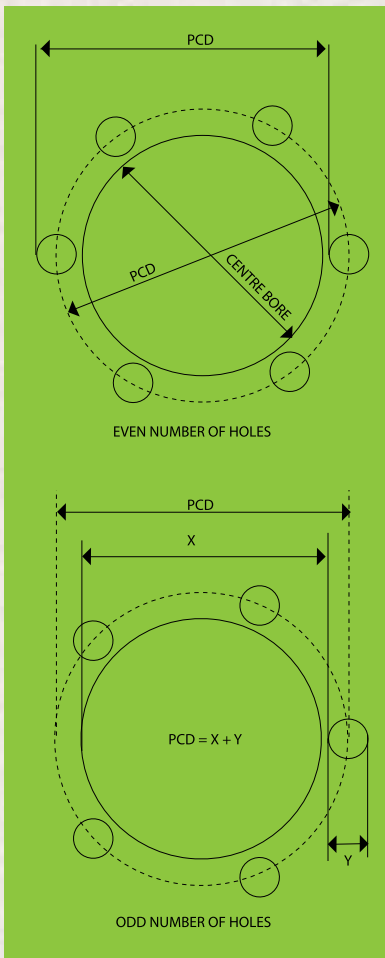

### Centre Bore and PCD Measurements

- **Centre Bore** is to locate the hub pilot in a spigot mount wheels (without countersink holes)
- **Stud Holes** are meant to locate the studs in the hub
- **Clamping Bolt Holes** are meant to fasten the two halves of the split rim
- **PCD ( Pitch Circle Diameter )** is the imaginary circle that passes through the centre of the stud holes or the clamping bolt holes
- The holes may be **EVEN** or **ODD** in numbers

### How to measure Centre bore diameter & Pitch Circle Diameter (PCD)

- **Centre Bore Diameter** is the distance between the inside edges of the centre bore passing through the centre line
- In case of **EVEN** number of holes, the measurement is to be taken from the outside edge of the hole to the inside edge of the opposite hole passing through the centre
- In case of **ODD** number of holes, two measurements are to be taken and added to arrive at the **PCD**
- Measurement '**X**' is taken from the inside edge of the centre bore to the inside edge of the opposite hole passing through the centre line
- Measurement '**Y**' is taken from the the inside edge of the centre bore to the outer edge of the nearby hole passing through the centre line

### Types of commonly used Fasteners for clamping Split rim halves

- Standard Hexagon Bolt with Hexagon Nut
- Standard Hexagon Bolt with Nyloc Nut
- Countersunk Bolt with Nyloc Nut
- Knurled Wheel bolt with Flange Nut

### A typical fastener size provides the following details

- Thread Diameter (in Metric or Inches)
- Pitch of the Thread (in Metric or Inches)
- Length of the Bolt (in Metric or Inches)
- Grade of the Bolt
- Type of Bolt
- Plating Requirement (Dry, oiled, Zinc, Dacromet, etc.,)

Countersunk Bolt      Hexagon Bolt      Knurled Wheel Bolt

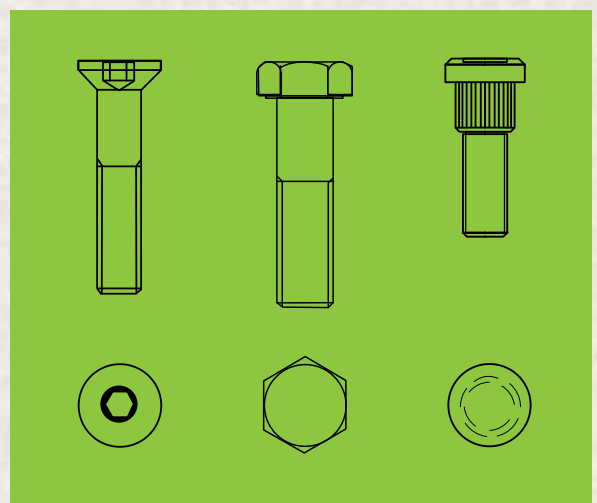

M12 x 1.5P, 30Lg, 10.9

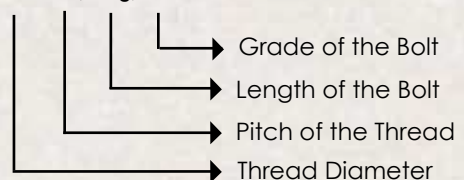

# FITMENT PRESS & FIXTURES

*Easy, Safe and Secure Fitment*



## FEATURES

- Emerald offers Industrial Fitment Press for mounting and demounting of Solid Resilients from 16" to 53" OD and Press-ons from 10" to 28" OD
- Offered with a complete set of fitment fixture to ensure Easy, Safe & Secure Fitment of tyres on the rims
- Fixtures for fitment include a set of Taper Cone, Pressing Cage & Base Plate for every ID profile in Solids & Press-ons
- Available in 80/100/120/200 Tons
- Compatible to fit all popular sizes in both Solid Resilient and Press on tyres

PARAMETERS	120T FITMENT PRESS	80T FITMENT PRESS	80T FITMENT PRESS
Capacity	120 T	80 T	200Ton
Construction	Fabricated H frame	Fabricated H frame	Fabricated H frame
Cylinder	ø250 mm x ø150 mm x 520 mm	ø220 mm x ø150 mm x 520 mm	350mm x 250mmx600mm
No. of cylinders	1	1	one
Stroke	400 mm	400 mm	600 mm
Day light gap	820 mm	820 mm	1140 mm
Over all width	1650 mm	1650 mm	2100 mm
Table size	ø950 mm	ø950 mm	950 mm
Moving plate	ø950 mm	ø950 mm	950 mm
Motor	3 Phase, 7.5 HP, 415 v AC, 50 Hz	3 Phase, 5.0 HP, 415 v AC, 50 Hz	10.0 HP; 415 V AC; 50 HZ ; 3 Phase
Load @ Max. Pr.	222 T	150 T	380 T
Safety	Fixed fencing at the back & Door type fencing at the front	Fixed fencing at the back & Door type fencing at the front	Fixed fencing at the back & Door type fencing at the front

## FITMENT FIXTURES FOR SOLID RESILIENTS



BASE PLATE



PRESSING CAGE



TAPER CONE

# DO'S & DON'TS

## FOR OPTIMAL PERFORMANCE OF INDUSTRIAL TYRES AND WHEELS

Strict adherence to the below recommended parameters will optimize the performance, save cost & ensure safety associated with the equipment, product & working personnel

### ✓ DO'S

- Select the right tyre & rim combination which would fit the equipment and meet the application requirements
- Study the application aspects – work environment & operating conditions thoroughly
- Confirm the Tyre size, Rim width, Tread pattern (Smooth/lug/Rib), Base type (Regular or lip) & PR of the tyre - as applicable
- Know the wheel rim type – Split/Single piece/ Multipiece
- Select the correct version which is 'application specific'
- Follow Proper fitment procedures
- Use proper fitment press; Tools & Accessories for fitment of Solids & Press ons
- Invest in Tyre Fitment press. Get it fitted with experienced tyre men
- Tighten fasteners to the required torque
- Look out for sharp edges , burrs on wheel rim which could damage the Tyre ID during fitment process
- Ensure proper radius in the entry point of the rim to facilitate fitment
- Use only Non-detergent Soap solutions in the ID of the tyre to facilitate fitment process
- Fitment fixtures to be seated on the band (metal) surface only and not on the rubberised portion in the sidewall during fitment of Press ons
- Rust oil to be applied on the band inner surfaces (only in the metal surface) in Press ons - if stored for long period of time to avoid corrosion
- All bolt/stud holes in a wheel rim should be fastened and no holes/studs should be left without fasteners
- Ensure sufficient ground & deck clearance for the tyre
- Ensure clearance between tyres in case of dual fitment
- Adhere to Equipment Maintenance Program
- Lubricate vehicle to ensure free-rolling
- Check wheel and axle alignment periodically
- Select proper equipment based on the loading & usage requirements
- Instruct operators to follow Good Driving Practices (GDP)
- Ensure to run on clean roads and gangways /aisles earmarked for equipment movement
- Look out for obstacles and follow route sign
- Ensure to work within the recommended speed & distance coverage factors
- Inspect tyres regularly for damages / injuries, stone / debris entrapment which would onset premature failure
- Attend to any abnormality seen in the wear or in the product immediately to avoid its premature failure
- Follow Dry, Ventilated, Dark, Cool (DVDC) storage practices
- Provide comprehensive information about the product requirements to the manufacturer to get their recommendations

### ✗ DON'TS

- Avoid Over speeding & Overloading
- Avoid long distance coverage at a stretch (< 2000 meters)
- Avoid bumps/Rails & work place floor hazards
- Avoid contact with oil/grease/chemical/ lubricants/acid etc.
- Avoid contact with sharp edged objects, Pallets, Girders etc.
- Avoid standing loads for long duration
- Avoid exposure to extreme temperatures
- Avoid sharp turns, skidding, rapid acceleration, harsh braking
- Avoid over-lubrication as spilled over oil on the floor or tyre is detrimental to the product's performance
- Avoid usage of oil, grease, lubricants to facilitate fitment process
- Avoid exposure to Sunlight/UV rays in general
- Avoid tampering base region of the tyre
- Avoid improper fitment practices
- Avoid rework of damaged rims. Suggest new replacement
- Avoid exposure of tyre to welding or heat spot both in fitted / unfitted condition with the rim



- Global Reach
- 📍 Sales Office / Warehouse
- 📍 Plant Location



[emeraldtyres.com](http://emeraldtyres.com)

## EMERALD TYRE MANUFACTURERS LIMITED

### REGISTERED OFFICE & MARKETING OFFICE

EMERALD HOUSE, PLOT NO.2, 2<sup>ND</sup> STREET, PHASE 1, PORUR GARDEN  
VANAGARAM, CHENNAI 600 095, TAMIL NADU, INDIA

### INTERNATIONAL

**E-MAIL** • [crm2@emeraldtyres.com](mailto:crm2@emeraldtyres.com) • [vkr@emeraldtyres.com](mailto:vkr@emeraldtyres.com)

**TEL** • +91 44 6646 0511 **MOBILE** • +91 94440 37201

### DOMESTIC

**E-MAIL** • [crm@emeraldtyres.com](mailto:crm@emeraldtyres.com) • [dek@emeraldtyres.com](mailto:dek@emeraldtyres.com)

**TEL** • +91 44 6646 0528 **MOBILE** • +91 94440 18905

### FACTORY

PLOT NO.78, 79 & 80, EPIP ZONE, SIPCOT INDUSTRIAL COMPLEX  
GUMMIDIPOONDI, TIRUVALLUR DISTRICT, TAMILNADU 601 201, INDIA  
**TEL** • +91 44 6790 5508

## EMERALD MIDDLE EAST FZE

SMBA0479 COMPASS BUILDING, AL SHOHADA ROAD  
AL HAMRA INDUSTRIAL ZONE-FZ, RAS AL KHAIMAH  
UNITED ARAB EMIRATES

**E-MAIL** • [asrajesh@emraldmiddleeast.com](mailto:asrajesh@emraldmiddleeast.com)

**TEL** • +971 50 115 2059

## EMERALD TYRES EUROPE B.V.

WARANDESTRAAT 1A, 9240 ZELE, BELGIUM (OFFICE)  
LINDESTRAAT 10, 9240 ZELE, BELGIUM (WAREHOUSE)

**E-MAIL** • [ddaniel@emeraldtyres.com](mailto:ddaniel@emeraldtyres.com)

**TEL** • +32 468 156 310

## SA RUBBER ENGINEERING (PTY) LTD.

LANCASTER ROAD, ACTONVILA  
POPLAR SECURE BUSINESS PARK, INIT 12, 16  
BENONI 1506, SOUTH AFRICA

**E-MAIL** • [vts@forktyre.co.za](mailto:vts@forktyre.co.za)

**TEL** • +27 66 449 1548

SOLID TYRE • PRESS-ON TYRE • CURED-ON TYRE (DIRECT BONDING WHEEL) • INDUSTRIAL PNEUMATIC TYRE  
BUTYL TUBE & FLAP • WHEEL RIM • FITMENT PRESS AND FIXTURES

EMERALD RESERVES THE RIGHT TO CHANGE THE CONTENTS OF THIS BROCHURE WITHOUT ANY PRIOR NOTICE